

# Joyous INC.

We believe in Creation, Quality and Honesty

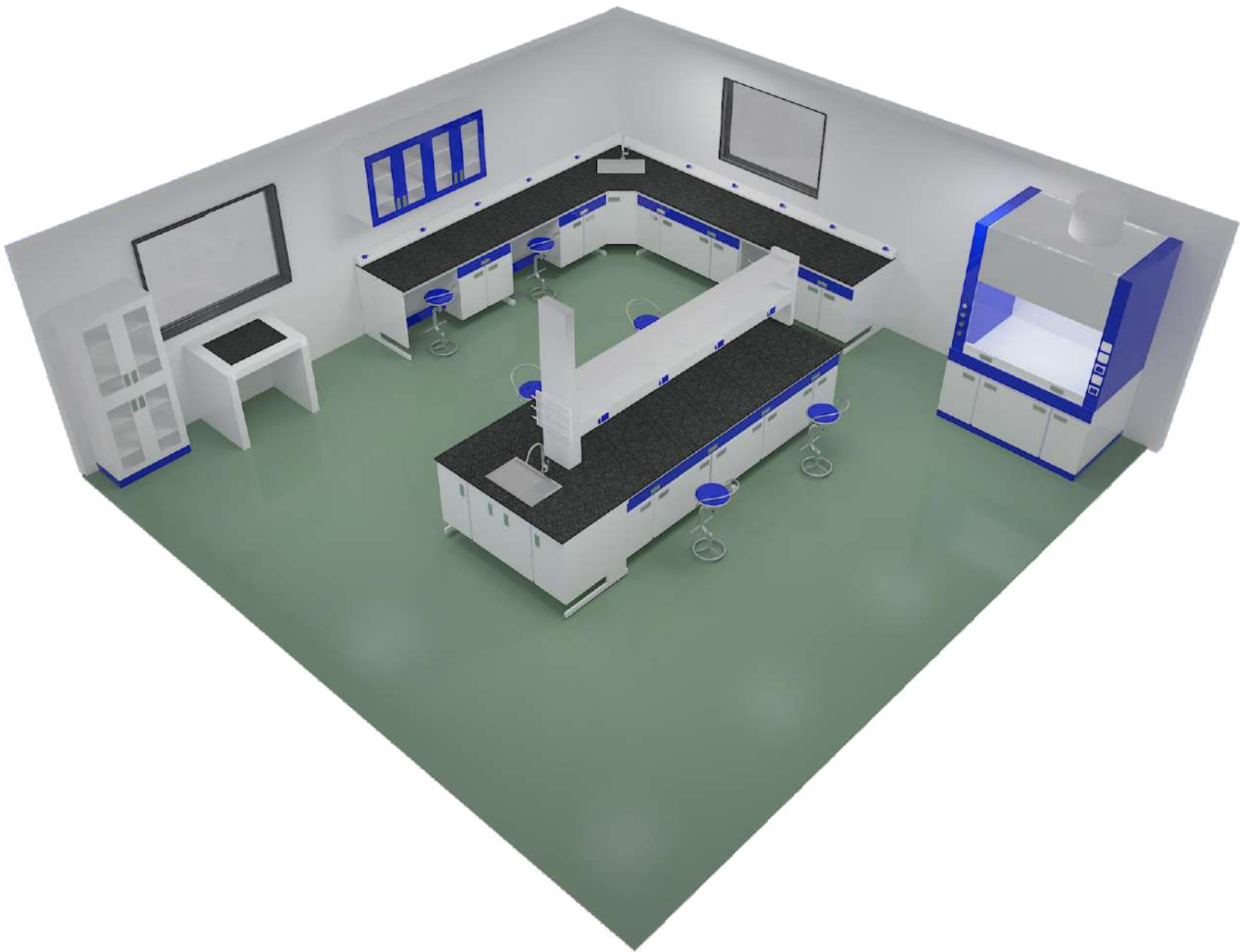

● Lab Furniture & Fume Hood

● Lab Turnkey Solutions

● SS Furniture

● Clean Room Partition

● Lab Fume Exhaust System

● Aluminium Profile Work Station

## About Us

**JOYOUS INC.** is a one of the growing company. We established in Ahmedabad, Gujarat, India. We have a vast experience in this field also have an expert team for developing products, problem solving capability and successfully erection work of projects to fulfil client's requirements.

We offer smart solution for lab projects like Lab Furniture, Lab Fume Hood, Lab Fume Exhaust System, Spot Extractor, Clean Room Furniture and Turnkey Solution. **JOYOUS INC.** provides the full range of service from design to engineering, through the final installation and erection.

## Our Mission

- To manufacture high quality & durable products to meet every technical aspects of the customer.
- Our key mission to build up and maintain a strong and joyful relationship with our valuable customer.
- Create Healthy & Toxic free work environment for people who are working in the laboratory.
- Our prime focus to build supreme quality laboratory with maximum space optimization.

**We are welcome and appreciate our customer's reviews and suggestions to make our products more batter and flexible as per their requirements.**



# Lab Furniture

## Application:

In the laboratories, role of the Working & Instrument tables are fix the instruments on it, Set up of R & D equipment's & Hot Oven. Moreover, it can be used for HPLC Machine & GC Machine with Computer set up.

As per the International laboratory standard & for comfort working, these tables should be designed in two working height (i) Standing working Height - 900mm / 3 Ft. (ii) Sitting working height – 750mm / 2.5 Ft.

This Furniture can be used in various kinds of industries like ● **Pharmaceutical Ind.** ● **Chemical Ind.** ● **Medical Research** ● **School & Collages** ● **Automobile Ind.** ● **Food / Dairy / Ice Cream Ind.** ● **Environmental Testing Laboratories. etc..**

## Technical Specifications:

### Material of Construction

- Galvanized Iron Sheet (G.I.) Construction
- Stainless Steel (SS) Construction
- Polypropylene (PP) Construction

### Table Top

- Natural Black Granite
- Stainless Steel
- Phenolic Resin
- Ceramic





## Type of Frame

**Joyous Inc.** design a rigid frame construction that assures solid installation to achieve high steadiness and can withstand 250 Kg. loads on the worktop.

Frame should be Epoxy powder coated as per our standard color combination or as per customer's choice with 60-80 micron thk.

### C' Type Frame Design

Our 'C' Frame structure is totally made from 60mmx30mm & 75mmx25mm rectangular M.S. pipe with 16 S.W.G. Wall thk.

### Pedestal Type Frame Design

Our Pedestal Frame structure totally made from 30mmx30mm Square M.S. pipe with 16 S.W.G. Wall thk.

### Plinth / Base Type Frame Design

Our Base Frame structure totally made from Galvanized Iron Sheet (G.I.) of 20 S.W.G. thk.

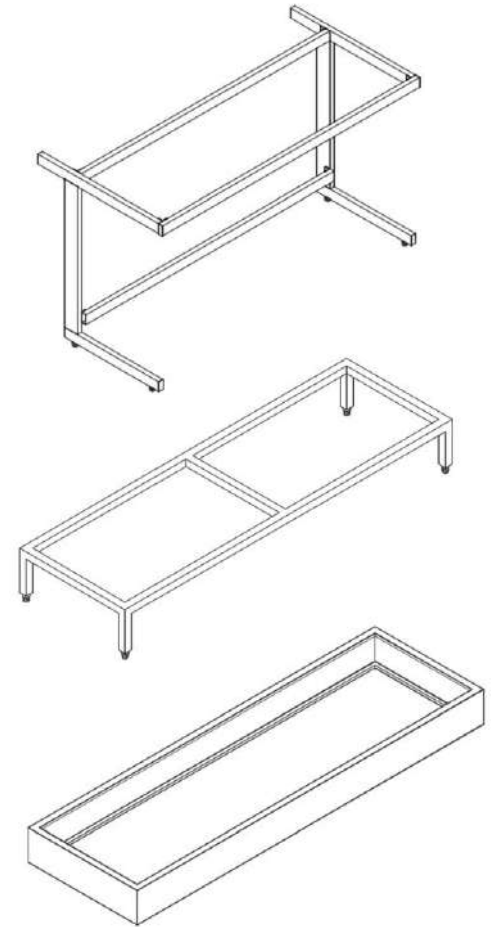

## Under Storage Cabinet / Modules

- We offer variety of under storage cabinet combinations to meet exact requirement of the user in laboratory.
- Our Standard sizes (Length in mm size) of modules are: **400/450/500/600/750/900.**
- Standard depth our modules **is 500mm.**
- We are using Hattich make Drawer Slider, Door Hinges and Lock in our storage cabinet
- Our Under storage cabinet should made from 20 S.W.G. Galvanized Iron (G.I.) / CRCA Sheet.
- Adjustable shelf can be provided with 75mm upper & down side height adjustment.
- Generally We offer following combinations like.
  1. Shutter with drawer and adjustable shelf.
  2. Full Shutter and adjustable shelf.
  3. Three / Four Drawers.

## Under Storage Cabinet / Modules Std. Heights Per Frame Design & Table Height

'C' Frame Table Height		Pedestal Frame Table Height		Base Frame Table Height	
900mm (3 Ft.)	750mm (2 Ft.)	900mm (3 Ft.)	750mm (2 Ft.)	900mm (3 Ft.)	750mm (2 Ft.)
650mm	500mm	700mm	550mm	750mm	600mm

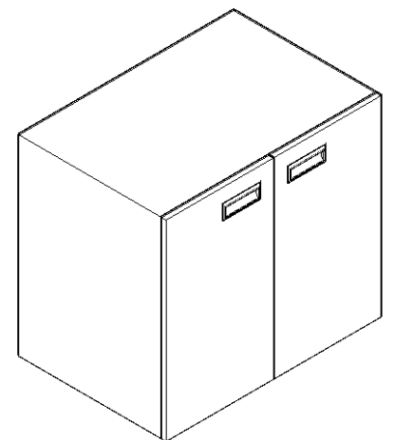
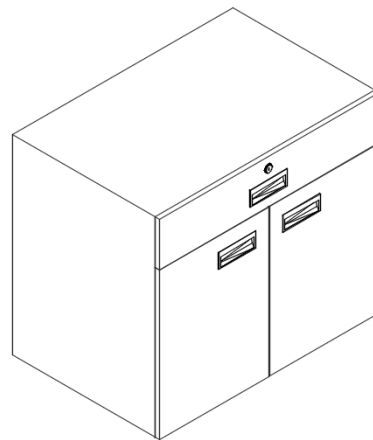
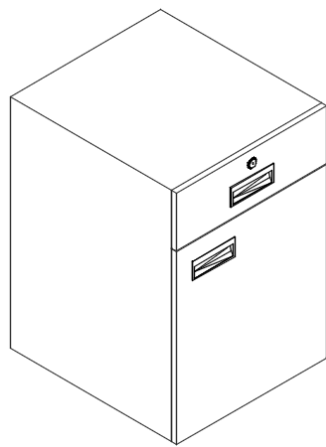
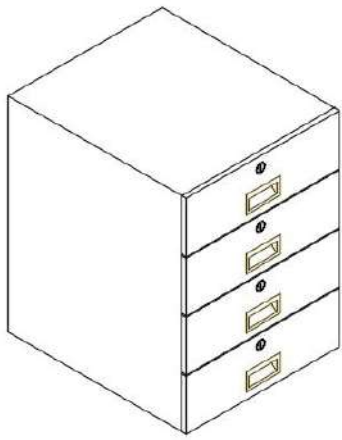

## Anti-Vibration Table

### Application:

- In the laboratories, main function of the Anti-vibration table is to take high accurate measurement of electronic scale.
- The Anti-Vibration table can provide vibration & shocks free working area for sensitive weighing scale in the laboratories.

### Technical Specifications:

#### Material of Construction

- **Frame** – 75mmx25mm, 16 S.W.G. Rec. MS Pipe
- **Covers** - Galvanized Iron (G.I.) 20 S.W.G. Sheet
- **Work Top** – Natural Granite
- Anti-Vibration rubber pads are providing on the top & bottom frame of the table.



# Storage Cabinets

## Wall / Overhead Storage Cabinet

We manufacture overhead storage cabinet to store general items in the laboratory. For properly mounting of overhead storage cabinet solid brick wall should be required.

### **Application:**

Overhead storage cabinet can be suitable for storage document files and any general items in the laboratory.

### **Technical Specifications:**

- Galvanized Iron (G.I.) – 20 S.W.G. Sheet
- Stainless Steel (SS) - 20 S.W.G. Sheet
- Hattich make Door Hinges and Lock.
- Adjustable shelf with 75mm upper & down side height adjustment.
- Our Standard sizes (Length in mm size) of modules are: 600/750/900.
- Standard depth of our cabinets is 400mm.



## File / Apparatus Storage Cabinet

### **Application:**

File / Apparatus storage cabinet can be suitable for storage Document files, Glassware and any General items in the laboratory.

### **Technical Specifications:**

- Galvanized Iron (G.I.) – 20 S.W.G. Sheet
- Stainless Steel (SS) - 20 S.W.G. Sheet
- Hattich make Door Hinges and Lock.
- Adjustable shelf with 75mm upper & down side height adjustment.
- Our Standard sizes (Length & Height in mm size) of modules are: Length – 900 / 1000 & Height – 1200 / 1800 / 2100 or as per customer's requirement.
- Standard depth of our cabinets is 450mm.
- Cabinets are available in 2/4 door with 5mm toughen glass and without glass.



## Chemical Storage Cabinet

### Application:

- The Chemical storage cabinets are mostly suitable to storage Toxic solvents & Chemicals in the laboratory.
- We offer cabinet is equipped with ventilation holes at side bottom and fume exhaust connection on the top to connect with exhaust blower for safety of user in the lab.

### Technical Specifications:

#### Material of Construction

- Galvanized Iron Sheet (G.I.) outer construction with 3mm Chemical resistance Phenolic resin sheet inner lining.
- Polypropylene (PP) Construction.

#### Accessories & Others

- Inner lining with chemical resistance phenolic resin 3mm sheet.
- Adjustable Polypropylene (PP) shelf with 75mm upper & down side height adjustment.
- Our Standard sizes (Length & Height in mm size) of modules are: Length – 900 / 1000 & Height – 1200 / 1800 or as per customer's requirement.
- Standard depth of our cabinets is 450mm.
- Cabinets are available in 2 / 4 door with 5mm toughen glass.



## Accessories



Lab Faucet



PP Sink



Lab Pegboard



Gas Valve



Eye Shower

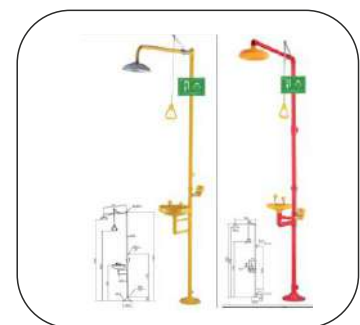

Safty Shower



# Lab Fume Hood

**Joyous Inc.'s** laboratory fume hoods are designed to protect user in the laboratory by preventing contaminants such as chemical vapors, dusts, mists and hazardous fumes from escaping into the laboratory environment. Laboratory fume hoods also provide lab personnel with a physical barrier to chemicals and their reactions by exhausting them to the outside air.

## Application:

- Fume hoods are mainly used for the R & D process where the hazardous fumes will be generated during the chemical reactions and will harmful for the laboratory Chemist / Scientist.
- Fume Hoods are very much useful for the industries like Pharmaceutical, Chemical, Clinic research centre. It is also used in Education industry.

## Technical Specifications

Our Fume Hoods are aerodynamic design to get stable face velocity for suction of high, Medium and low density fumes generate in the Fume Hood.

## Material of Construction

- CRCA / Galvanized Iron Sheet (G.I.)
- Stainless Steel (SS)
- Polypropylene (PP)

## Accessories & Others

- Fume Hood Inner lining with chemical resistance phenolic resin 6mm sheet / SS 304 Sheet / PP Sheet.
- Sash of 5mm toughens glass with counter balance to achieve easy sliding movement
- Work surface - Natural Granite / Ceramic / P.P / SS.
- Utility Valve – Water, Gas, Nitrogen & Vacuum
- LED Tube Light for Fume Hood

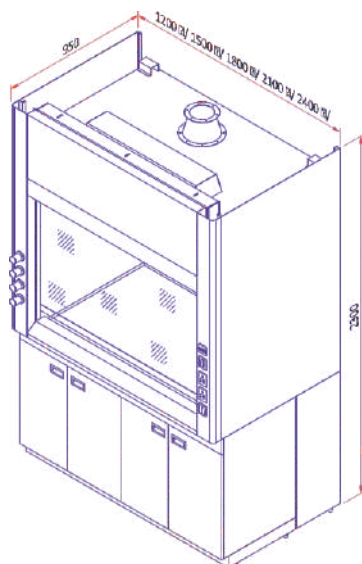

STD Bench Top Fume Hood

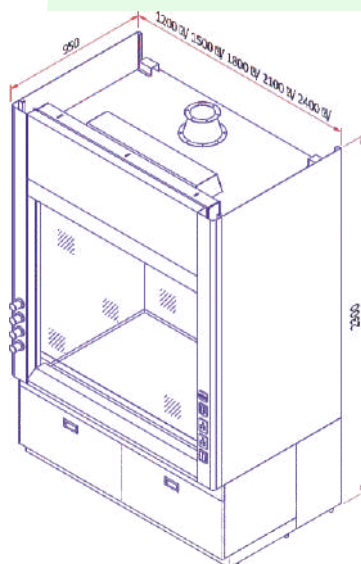

Low Bench Fume Hood

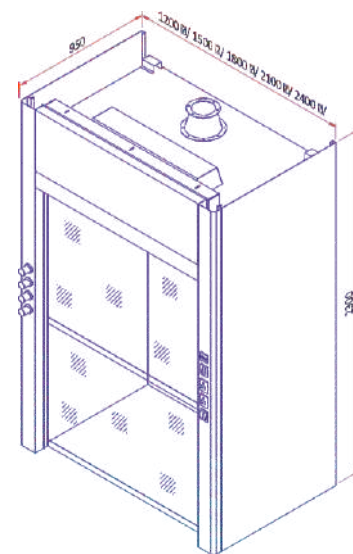

Walk-in Fume Hood



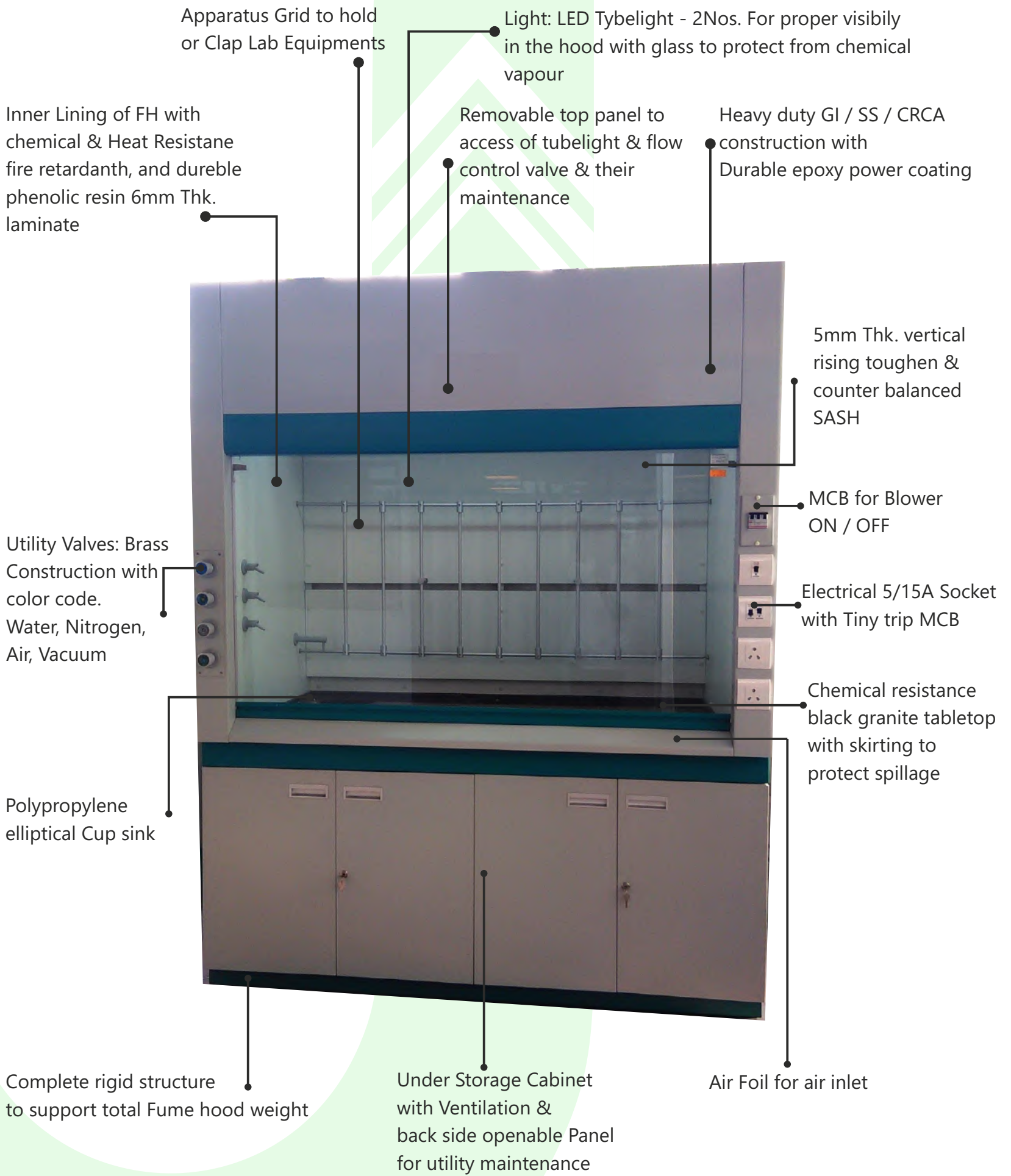

# Fume Spot Extractor Arm

**Joyous Inc.** offer the best solution of fume spot extraction from working processes in the laboratory. We have a rich experience to design and installation of fume extraction system in the laboratories to prevent lab user from the hazardous vapours and substances. With our expertise we can create a healthy and chemical smell free working environment in the laboratory.

## Application:

- Fume Spot extractor arm is mainly used in chemical environment, at where the working processes couldn't possible in the fume cabinet and can develop disturbing fumes, aerosols and bad smells.
- Fume spot extraction is used in various industrial applications like – Chemical Labs, Pharmaceutical labs, R & D Labs, Production area where dust and fumes are generated.

## Technical Specifications

### Material of Construction

- Polypropylene (PP)
- Aluminium (AL)



**Ceiling Mounted Spot Extractor**



**Wall Mounted Spot Extractor**



# Exhaust Blower & Scrubber

**Joyous Inc.** offer variety of Exhaust Blowers to exhaust hazardous fumes, dust & vapours from the laboratory through Fume Hoods, Spot Extractor System and Ventilation System.

We also offer a Scrubber System to prevent environment from hazardous chemical and fumes which are exhausted from labs to the atmosphere.

## Application:

- Blowers are connected with the Fume hoods or Spot extractor arm with chemical resistance piping.
- Scrubbers are generally used to neutralize hazardous chemical fume generated in the lab during process.
- In the Pharma & Chemical industries very harmful gases and fume are generated during the process that will directly exhaust in to the atmosphere. They are very dangerous for us and our atmosphere. By connecting the scrubber system with the exhaust blower we can neutralize the harmful gases and fume to save our environment.

## Blower

### Technical Specifications

#### Material of Construction

- Polypropylene (PP) – Corrosion Resistance
- Galvanised steel
- Stainless Steel (SS)

#### Types of Blower

- Centrifugal blower
- In-Line Centrifugal Blower

## Scrubber

### Technical Specifications

#### Material of Construction

- Polypropylene (PP) – Corrosion Resistance

#### Types of Scrubber

- Wet Scrubber
- Dry Scrubber





# Laboratory Turnkey Solutions

## Our Services

### Clean Room Solution

- Modular Panel
- Ceiling
- Door
- Accessories

### Electrification Work

### Utility Piping Work

### Cleanroom Equipment

### Aluminium Partition Work

### Ceiling Work

### Epoxy Flooring Work

### Painting Work

### Structural Work

## About Us

Joyous Inc. offers value-engineered turnkey laboratory solution to fit your project requirements.

- Joyous Inc. providing complete integrated Laboratory Turnkey Solutions for the following industries: **Pharmaceutical Ind., Chemical Ind., Medical Research Laboratories, School & Collages laboratories, Automobile Ind., Food / Dairy / Ice Cream Ind., and Environmental Testing Laboratories** accompanied by design, planning, manufacturing, Site co-ordination, installation and erection as well as complete site management.
- We are "one stop" solution provider for integrated laboratory turnkey solutions this will help the client to have single point of contact for the entire duration of the project from design to project execution.
- We have a vast experience with a strong team of contractor-partners and qualified professionals, to manage and deliver high quality products and services by optimizing timelines, application of specialized skillset, and accelerating construction schedules
- We believe in the development and implementation of turnkey projects are executed exactly in line with customer's individual requirement at prime quality.



Ceiling Work: Gypsum POP(Plaster of Paris) & Clean room Walkable & non Walkable ceiling

Utility piping work: Water, Gas, Etc.

Clean room view panel

Lab Furniture: Island Table, working table, storage cabinet, anti-vibration table, etc.

Epoxy Flooring work

Electrification work Single Phase & Three Phase wiring

Fume exhaust system with chemical resistance PP+FRP piping Blower & Scrubber

Fume hood: STD Table Top, Low Bench & Walk-in

Clean Room Partition/ Alu. Partition / Wall Color

Lab Stool & Chairs



# Services & AMC

## Services

In the industry, it is necessary to complete the installation and erection work of the product without any hesitation and trouble.

**Joyous Inc. offers complete installation service** by our highly experience, skilled and trained technical team. Our Technical team will help and guide the customer for proper utilization of their lab space along with their requirements for the lab.

Also we have more than 7 years of experience in the Food & Dairy industry. **We offer maintenance, repair, new developing of parts, Conveyer for food and dairy machineries.**

## AMC

We are committed to support our customers throughout the product life cycle. **We offers annual maintenance contract after the expiry of the warranty period of the furniture and equipment.** Main Aim of the Annual maintenance is to maintain equipment in the original manufacturing standard.

## Photo Gallery







# SS Furniture



## Clienteles



# Joyous INC.

We believe in Creation, Quality and Honesty

 [www.joyousinc.in](http://www.joyousinc.in)

 +91 94265 26283 | +91 81560 58977

 [gaurav@joyousinc.in](mailto:gaurav@joyousinc.in) | [joyousinc.in@gmail.com](mailto:joyousinc.in@gmail.com)

 27, Abhishilp Industrial Park, B/H Vepari Mahamandal, Odhav, Ring Road, Oadhav, Ahmedabad-382415

